



Service Manual

A-400

3 HP / Wet Automatic Control

Installation

1. Place the shipping carton in the desired location. Remove the unit from the shipping carton.
2. Separate the back from the front of the unit. Place the unit out of the way.



NOTE

This unit requires a regulated air and water supply. Filters are highly recommended.

MOUNTING OPTION 1

- A. Place the back plate on the wall, level and secure it to the wall.
- B. Drill a hole for the umbilical tubing and feed the umbilical through the hole in the wall and mount the unit to the back plate.
- C. Install optional master valve assemblies, with filter and regulator, onto the manual shut-off valves. (Pressures are preset at the factory: 80 psi air, 40 psi water).
- D. Connect the supply tubings to the appropriate air and water supply lines.

MOUNTING OPTION 2

- A. Place the back plate on the wall, level and secure it to the wall.
- B. Mount the unit to the back plate, letting the umbilical tubing hang down.
- C. Install optional master valve assemblies, with filter and regulator, onto the manual shut-off valves. (Pressures are preset at the factory: 80 psi air, 40 psi water).
- D. Connect the supply tubings to the appropriate air and water supply lines.

Final Adjustments

- Check air pressure, adjust to 80 psi if necessary.
- Check water pressure, adjust to 40 psi if necessary.
- Test handpieces for proper function.
- Test syringe for proper pressure and function.

A-400

Operation

1. Turn on the master switch located on the right side of the faceplate.
2. The handpiece is automatically activated when lifted from the holder.
3. Depress the foot control to activate each handpiece. Pressure is shown on the gauge for the handpiece being used.
4. Individual handpiece pressure adjustments are located on the front panel for easy HP adjustment. To adjust the pressure to each handpiece:
 - a. Turn adjustment screw *clockwise* to decrease the handpiece pressure.
 - b. Turn adjustment screw *counter-clockwise* to increase the handpiece pressure.

CAUTION



When adjusting the handpiece pressure, do not over-tighten the screws. Damage may result.

5. Handpiece coolant water can be turned on or off with the toggle switch located on the left side of the faceplate.
6. Water coolant flow adjustment is located to the right of the water coolant toggle switch.

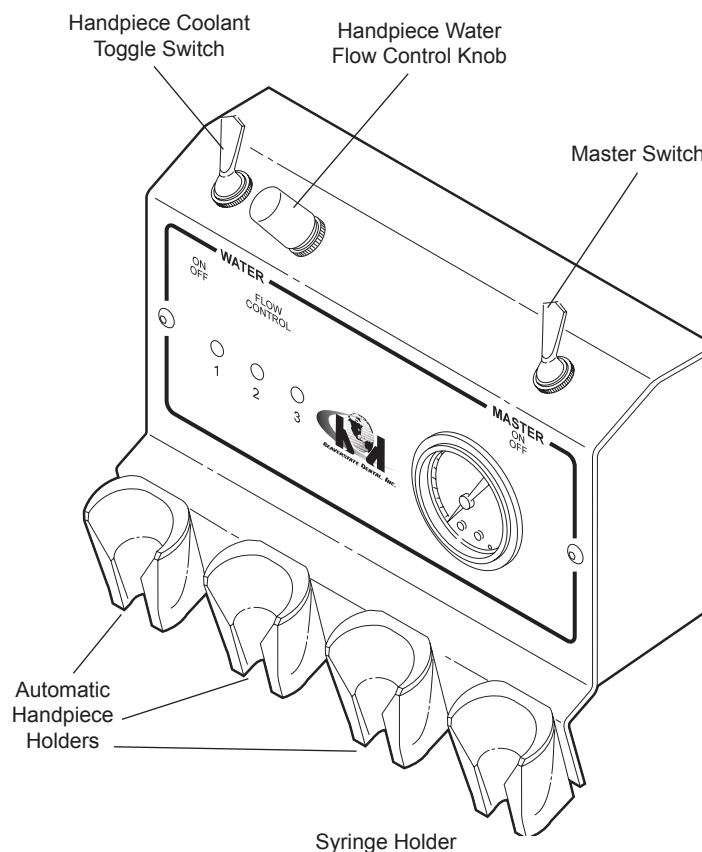

Control Panel A-400

Troubleshooting

Symptom Handpiece lacks power.

Possible Causes

- A. Improper supply pressure from compressor (80 psi).
- B. Check handpiece pressure adjustment on unit.
- C. Air filter may be plugged.
- D. Pinched supply tubing.
- E. Defective handpiece gasket at connection with tubing.
- F. Defective handpiece.

Symptom Water coolant does not shut off when foot control is released.

Possible Causes

- A. Adjust air pressure to 80 psi—water pressure to 40 psi.
- B. Foot control is not exhausting.
- C. Defective water relay valve.
- D. Defective auto block gasket
- E. Defective flow valve

Symptom More than one handpiece is operating.

Possible Causes

- A. Handpiece is not all the way in the holder.
- B. Improper adjustment on pilot valve in the handpiece holder.

Symptom Insufficient water coolant.

Possible Causes

- A. Adjust coolant flow valve.
- B. Water filter may be plugged.
- C. Handpiece may be plugged.
- D. Pinched supply tubing.
- E. Improper adjustment of water relay valve.

Symptom Water coolant is running from handpiece while in the holder.

Possible Causes

- A. Water pressure too high.
- B. Air pressure too low.
- C. Handpiece holder out of adjustment.

Symptom Water coolant is running continuously.

Possible Causes

- A. Purge switch is on (on applicable systems).
- B. Handpiece holder out of adjustment.
- C. Defective water relay valve.
- D. Water pressure to high.

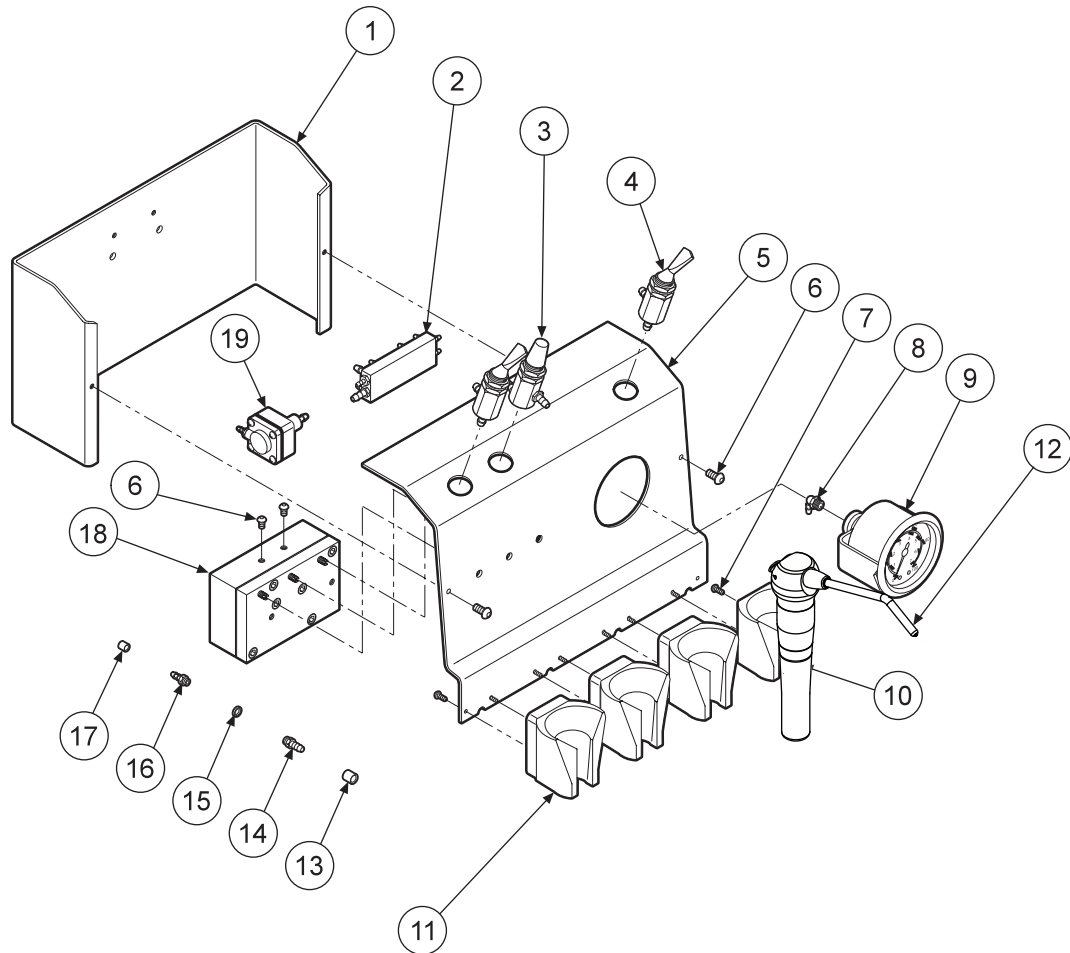

ITEM	PART DESCRIPTION	PART NUMBER	QTY	ITEM	PART DESCRIPTION	PART NUMBER	QTY	ITEM	PART DESCRIPTION	PART NUMBER	QTY
1	Backplate.....	103-300	1	8	Plastic Elbow, 1/16".....	022-039	1	15	Plastic Washer, 1/4".....	003-001	
2	Handpiece Manifold.....	023-023	1	9	Gauge.....	026-002	1	16	Barb, 10-30 x 1/16".....	022-009	
3	Needle Flow Valve.....	121-000	1	10	Universal Handpiece Holder.....	141-006	1	17	Ferrule, 1/8".....	117-007	
4	3-way Toggle Valve.....	120-000	2	11	Automatic Handpiece Holder....	122-049	3	18	Automatic Handpiece Block.....	125-030	1
5	Faceplate.....	103-301	1	12	Syringe.....	113-400	6	19	Water Relay Valve.....	123-000	2
6	Screw, 6-32 x 1/4".....	001-133	4	13	Ferrule, 1/4".....	117-008					
7	Screw, #4 x 3/8".....	001-135	8	14	Barb, 10-30 x 1/8".....	022-010					

**AUTOMATIC HANDPIECE CONTROL
A-400**

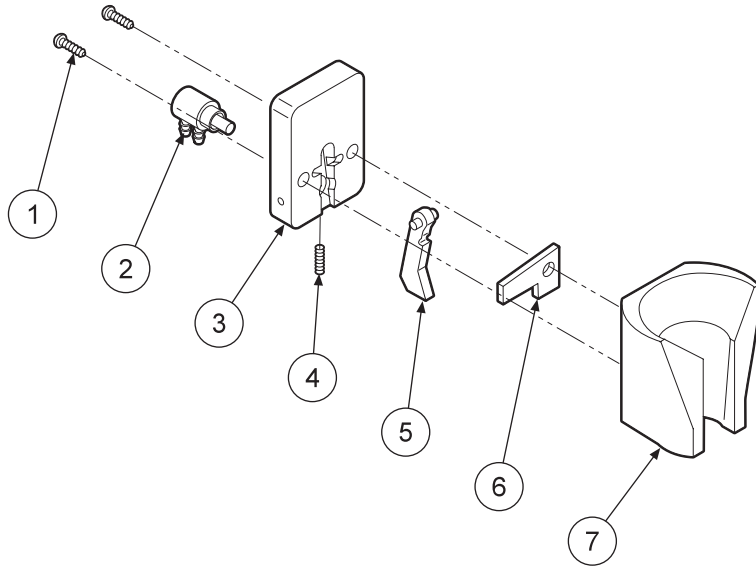

ITEM	PART DESCRIPTION	PART NUMBER	QTY
1	Screw, #4 x 3/8"	001-145	2
2	Automatic Holder Valve	122-031	1
3	Holder Backplate	122-012	1
4	Set Screw, 4-40 x 3/16"	005-001	1
5	Handpiece Actuator Lever	122-014	1
6	Holder Spacer	141-012	1
7	Molded Handpiece Holder	141-011	1

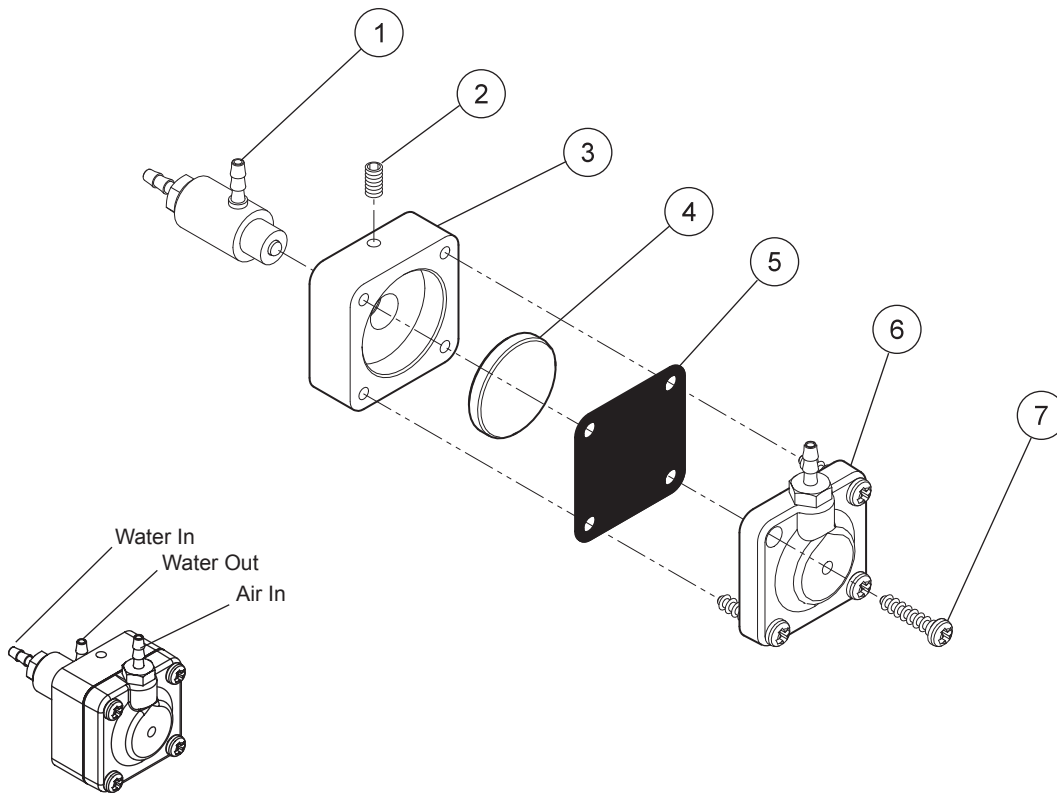
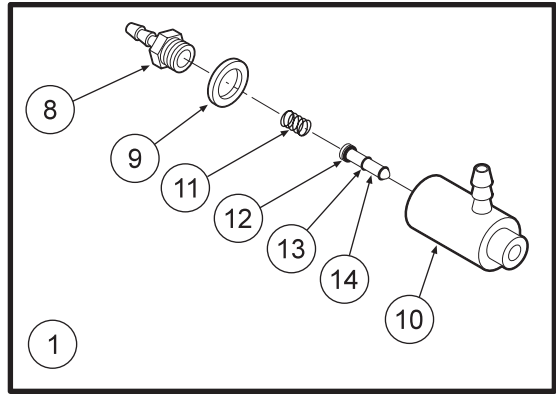

Water Relay Valve 123-000

ITEM	PART DESCRIPTION	PART NUMBER	QTY
1	Cartridge Body Assembly.....	123-018	1
2	Set Screw, 4-40 x 5/8".....	005-028	1
3	Body.....	123-013	1
4	Piston.....	123-014	1
5	Diaphragm.....	123-016	1
6	Cap.....	123-012	1
7	Screw, #6 x 1/2".....	001-017	4
8	Barb, 10-32 x 1/16".....	022-009	1
9	Plastic Washer, 1/4".....	003-001	1
10	Valve Body.....	123-017	1
11	Spring.....	008-011	1
12	O-Ring, 002.....	017-502	1
13	O-Ring, 001.....	017-501	2
14	Stem.....	123-015	1

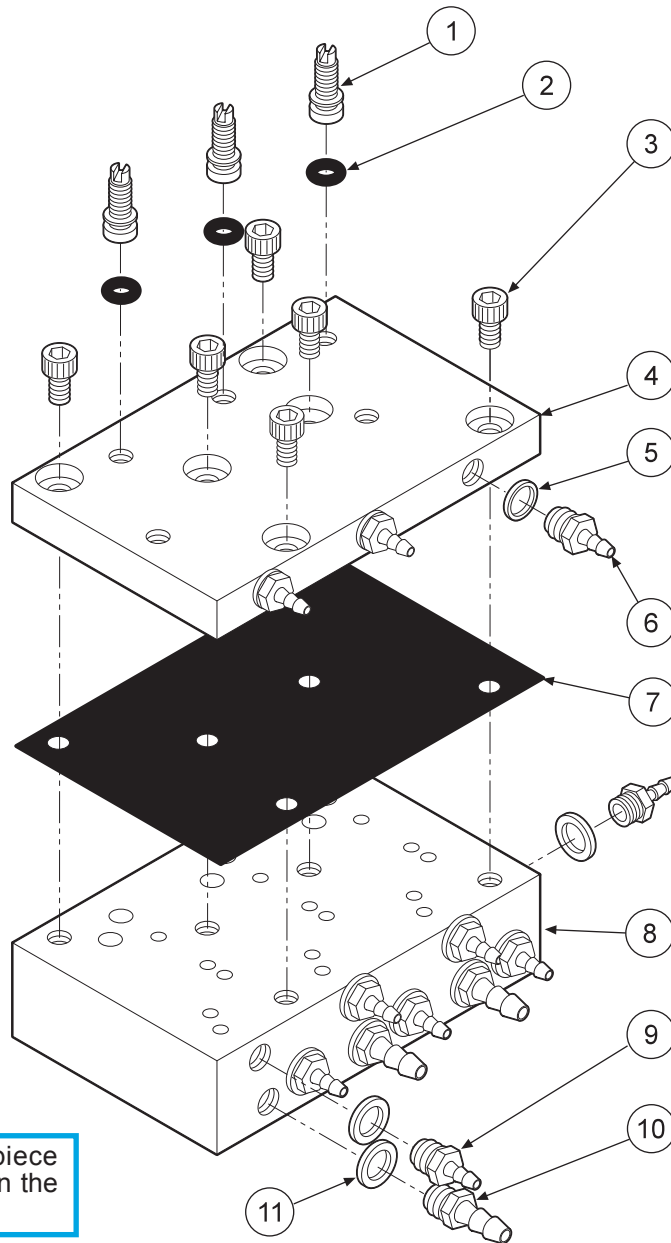

CAUTION
When adjusting the handpiece pressure, do not over-tighten the screws. Damage may result.

The automatic control block is the control center for your dental unit.

Individual handpiece pressure adjustments are located on the autoblock. To adjust the pressure to each handpiece:

- a. Turn adjustment screw clockwise to decrease the handpiece pressure.
- b. Turn adjustment screw counter-clockwise to increase the handpiece pressure.

ITEM	PART DESCRIPTION	PART NUMBER	QTY
1	Adjusting Stem.....	125-023	3
2	O-Ring, 021.....	017-021	3
3	Screw, 6-32 x 1/4".....	001-131	7
4	Cap.....	125-032	1
5	Plastic Washer, 8-32 x 1/16".....	003-030	3
6	Barb, 8-32 x 1/16".....	022-040	3
7	Diaphragm.....	125-016	1
8	Body.....	125-031	1
9	Barb, 10-32 x 1/16".....	022-009	9
10	Barb, 10-32 x 1/8".....	022-010	4
11	Plastic Washer, 1/4".....	003-001	13

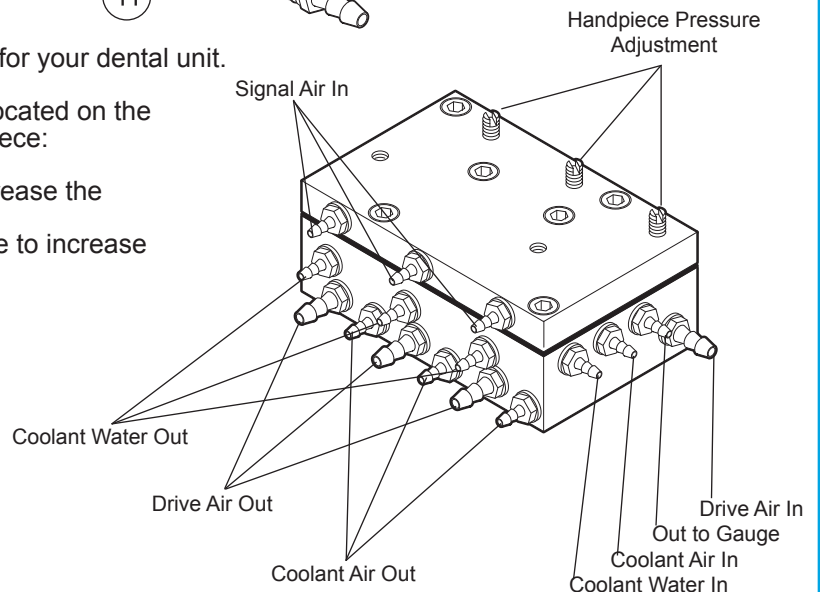

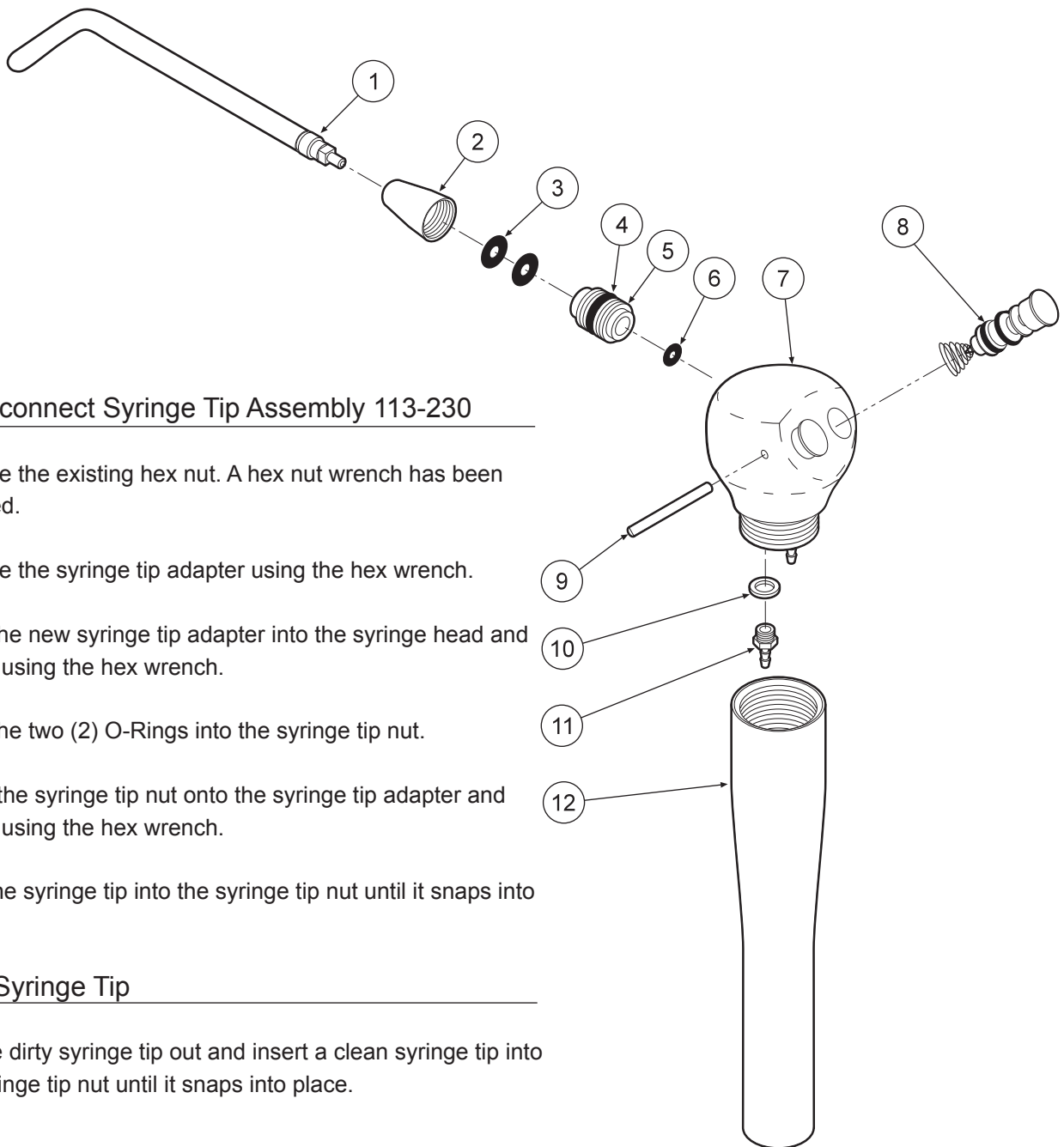

Quick-disconnect Syringe Tip Assembly 113-230

1. Remove the existing hex nut. A hex nut wrench has been provided.
2. Remove the syringe tip adapter using the hex wrench.
3. Insert the new syringe tip adapter into the syringe head and tighten using the hex wrench.
4. Place the two (2) O-Rings into the syringe tip nut.
5. Screw the syringe tip nut onto the syringe tip adapter and tighten using the hex wrench.
6. Push the syringe tip into the syringe tip nut until it snaps into place.

Replace Syringe Tip

1. Pull the dirty syringe tip out and insert a clean syringe tip into the syringe tip nut until it snaps into place.

ITEM	PART DESCRIPTION	PART NUMBER	QTY
1	Syringe Tip	113-030	1
2	Syringe Tip Nut	113-402	1
3	O-Ring, 006	017-006	2
4	O-Ring, 228-040	017-023	1
5	Syringe Tip Adapter	113-227	1
6	O-Ring, 003	017-003	1
7	Syringe Head	113-405	1
8	Syringe Button Repair Kit	113-403	2
9	Pin, Syringe Cartridge	113-008	1
10	Plastic Washer, 8-32	003-030	2
11	Barb, 8-32 x 1/16"	022-040	2
12	Syringe Handle	113-236	1

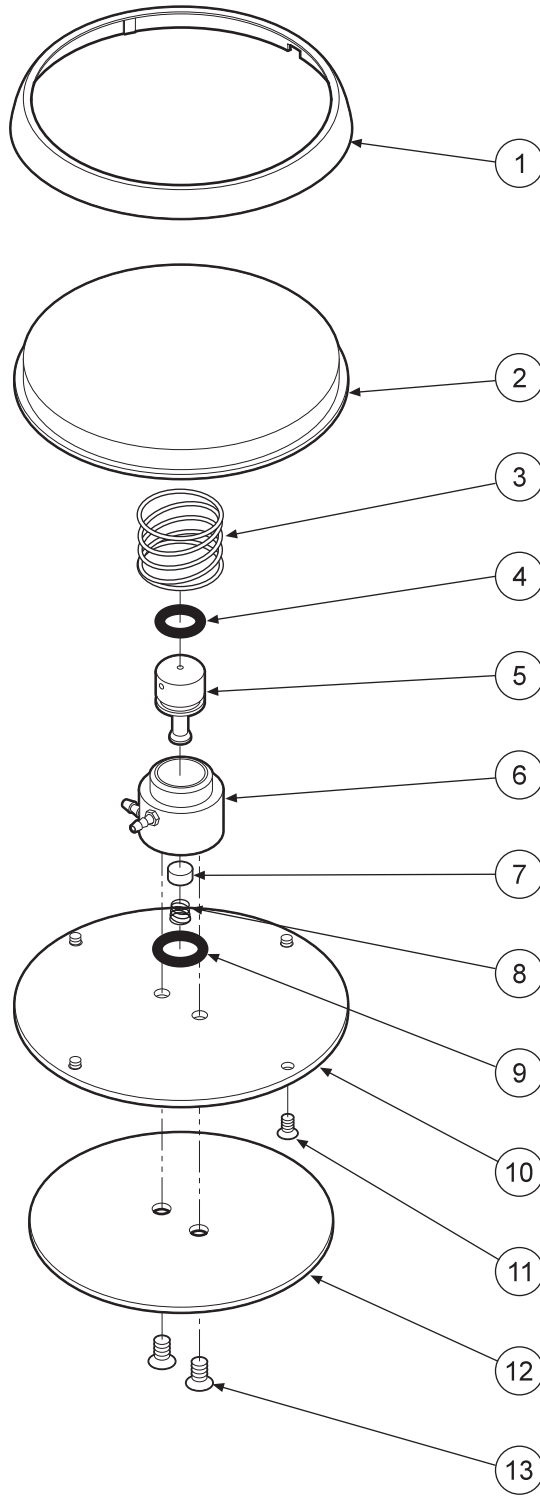

ITEM	PART DESCRIPTION	PART NUMBER	QTY
1	Ring.....	126-002	1
2	Cover.....	126-001	1
3	Spring.....	008-005	1
4	O-Ring, 012.....	017-012	1
5	Stem.....	126-005	1
6	Body.....	126-004	1
7	Poppet.....	126-006	1
8	Spring.....	008-006	1
9	O-Ring, 013.....	017-013	1
10	Baseplate.....	126-003	1
11	Screw, 4-40 x 1/4".....	001-005	4
12	Rubber Pad.....	126-007	1
13	Screw, 6-32 x 1/4".....	001-004	2
	Repair kit.....	126-025	