



Service Manual

A-222

2 HP Wet / Automatic Control

Installation

1. Place the shipping carton in the desired location. Remove the unit from the shipping carton.
2. Separate the back from the front of the unit. Place the unit out of the way.



NOTE

This unit requires a regulated air and water supply. Filters are highly recommended.

MOUNTING OPTION 1

- A. Place the back plate on the wall, level and secure it to the wall.
- B. Drill a hole for the umbilical tubing and feed the umbilical through the hole in the wall and mount the unit to the back plate.
- C. Install optional master valve assemblies, with filter and regulator, onto the manual shut-off valves. (Pressures are preset at the factory: 80 psi air, 40 psi water).
- D. Connect the supply tubings to the appropriate air and water supply lines.

MOUNTING OPTION 2

- A. Place the back plate on the wall, level and secure it to the wall.
- B. Mount the unit to the back plate, letting the umbilical tubing hang down.
- C. Install optional master valve assemblies, with filter and regulator, onto the manual shut-off valves. (Pressures are preset at the factory: 80 psi air, 40 psi water).
- D. Connect the supply tubings to the appropriate air and water supply lines.

Final Adjustments

Check air pressure, adjust to 80 psi if necessary.
Check water pressure, adjust to 40 psi if necessary.
Test handpieces for proper function.
Test syringe for proper pressure and function.

Operation

1. The handpiece is automatically activated when lifted from the holder.
2. Depress the foot control to activate each handpiece. Pressure is shown on the gauge for the handpiece being used.
3. Individual handpiece pressure and syringe adjustments are located on the flow control block inside the unit. Access to the flow control is from the bottom of the unit. To adjust the pressure to each handpiece:
 - a. Turn adjustment screw *clockwise* to decrease the handpiece pressure.
 - b. Turn adjustment screw *counter-clockwise* to increase the handpiece pressure.



CAUTION

When adjusting the handpiece pressure, do not over-tighten the screws. Damage may result.

4. Handpiece coolant water can be turned on or off with the toggle switch located on the left side of the faceplate.
5. Water coolant flow adjustment is located to the right of the water coolant toggle switch.

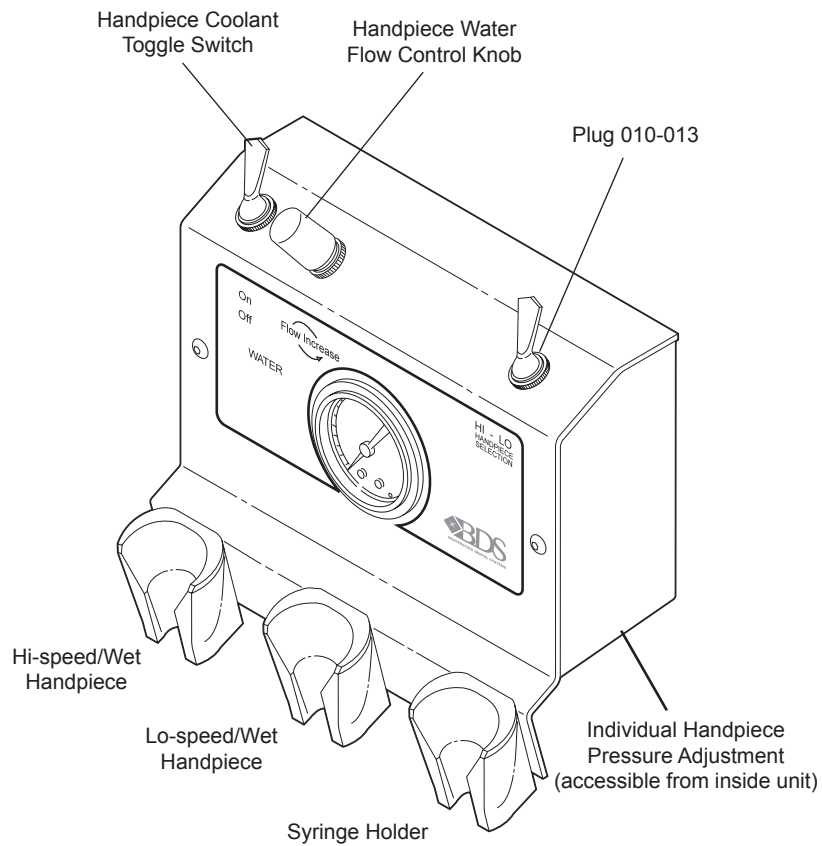

Control Panel A-220/A-222

Troubleshooting

Symptom Handpiece lacks power.

Possible Causes

- A. Improper supply pressure from compressor (80 psi).
- B. Check handpiece pressure adjustment on unit.
- C. Air filter may be plugged.
- D. Pinched supply tubing.
- E. Defective handpiece gasket at connection with tubing.
- F. Defective handpiece.

Symptom Water coolant does not shut off when foot control is released.

Possible Causes

- A. Adjust air pressure to 80 psi—water pressure to 40 psi.
- B. Foot control is not exhausting.
- C. Defective water relay valve.
- D. Leaking flow valve

Symptom More than one handpiece is operating.

Possible Causes

- A. Handpiece is not all the way in the holder.
- B. Improper adjustment on pilot valve in the handpiece holder.
- C. Defective shuttle valve to gauge.

Symptom Insufficient water coolant.

Possible Causes

- A. Adjust coolant flow valve.
- B. Water filter may be plugged.
- C. Handpiece may be plugged.
- D. Pinched supply tubing.
- E. Improper adjustment of water relay valve.

Symptom Water coolant is running from handpiece while in the holder.

Possible Causes

- A. Water pressure too high.
- B. Air pressure too low.
- C. Handpiece holder out of adjustment.

Symptom Water coolant is running continuously.

Possible Causes

- A. Purge switch is on (on applicable systems).
- B. Handpiece holder out of adjustment.
- C. Defective water relay valve.
- D. Water pressure too high.

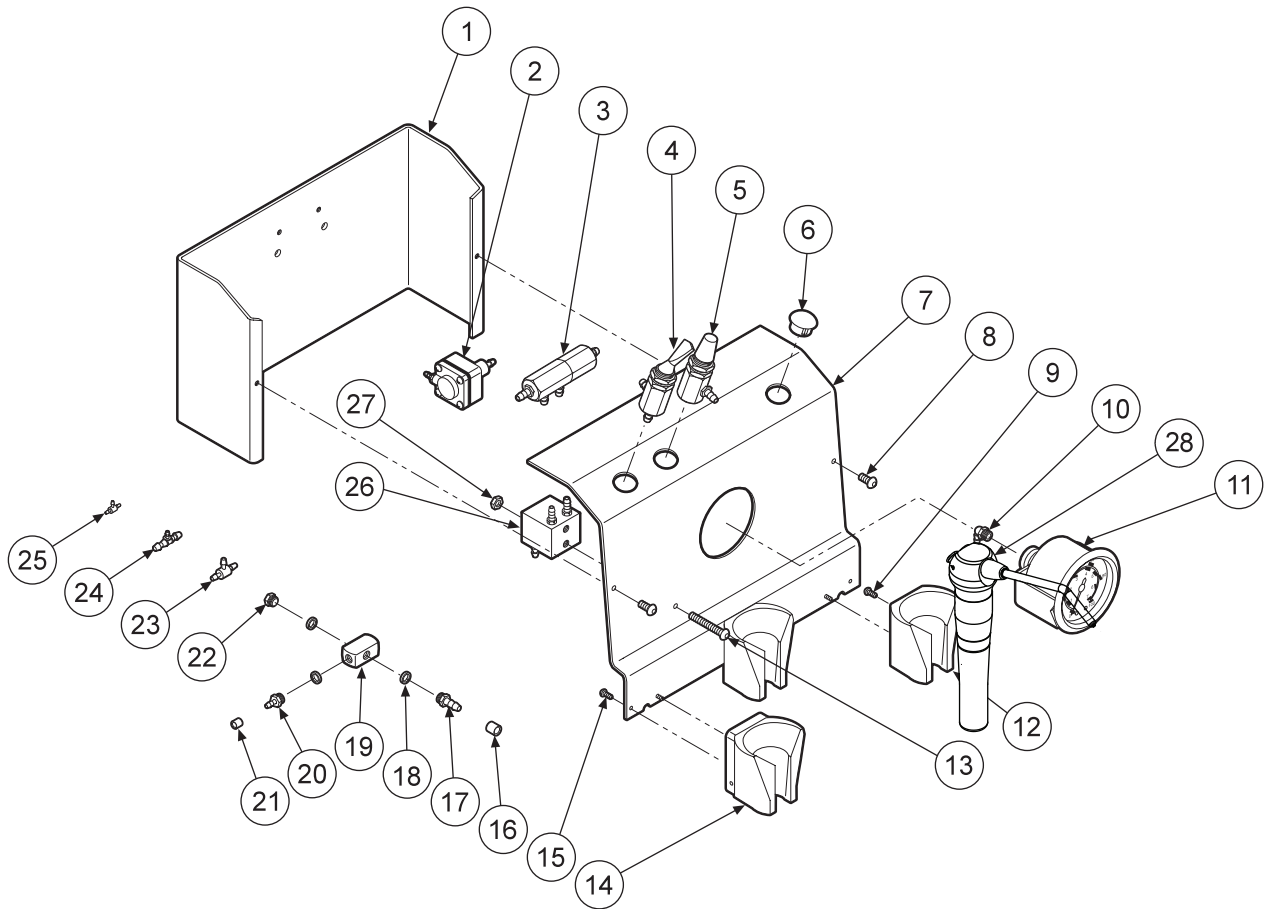

ITEM	PART DESCRIPTION	PART NUMBER	QTY	ITEM	PART DESCRIPTION	PART NUMBER	QTY	ITEM	PART DESCRIPTION	PART NUMBER	QTY
1	Chassis.....	103-200	1	11	Gauge.....	026-002	1	20	Barb, 10-30 x 1/16".....	022-009	
2	Water Relay Valve.....	123-000	2	12	Universal Handpiece Holder.....	141-006	2	21	Ferrule, 1/8".....	117-007	
3	Routing Valve.....	014-007	1	13	Screw, 6-32 x 1".....	001-147	1	22	Plug, 10-32.....	001-001	1
4	3-Way Toggle Valve.....	120-015	1	14	Automatic Handpiece Holder.....	122-049	1	23	Shuttle Valve.....	014-012	1
5	Needle Flow Valve.....	121-000	1	15	Screw, 6-32 x 3/8".....	001-135	2	24	Plastic Tee, 1/8" x 1/16" x 1/8".....	022-049	1
6	Plug, 1/2".....	010-013	1	16	Ferrule, 1/4".....	117-008		25	Plastic Tee, 1/16".....	022-033	1
7	Faceplate.....	103-201	1	17	Barb, 10-30 x 1/8".....	022-010		26	Syringe Block.....	113-018	1
8	Screw, 6-32 x 1/4".....	001-133	2	18	Plastic Washer.....	003-001		27	Nut, 6-32.....	002-004	1
9	Screw, # 4 x 3/8".....	001-135	4	19	4-Way Cross.....	023-008	1	28	Syringe.....	113-400	1
10	Plastic Elbow, 1/16".....	022-039	1								

AUTOMATIC HANDPIECE CONTROL, BOTH WET
A-222

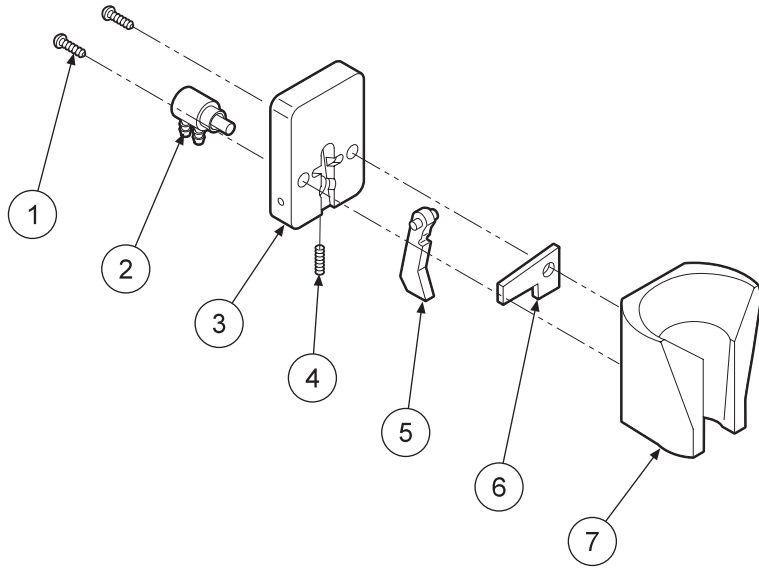

ITEM	PART DESCRIPTION	PART NUMBER	QTY
1	Screw, #4 x 3/8"	001-145	2
2	Automatic Holder Valve	122-031	1
3	Holder Backplate	122-012	1
4	Set Screw, 4-40 x 3/16"	005-001	1
5	Handpiece Actuator Lever	122-014	1
6	Holder Spacer	141-012	1
7	Molded Handpiece Holder	141-011	1

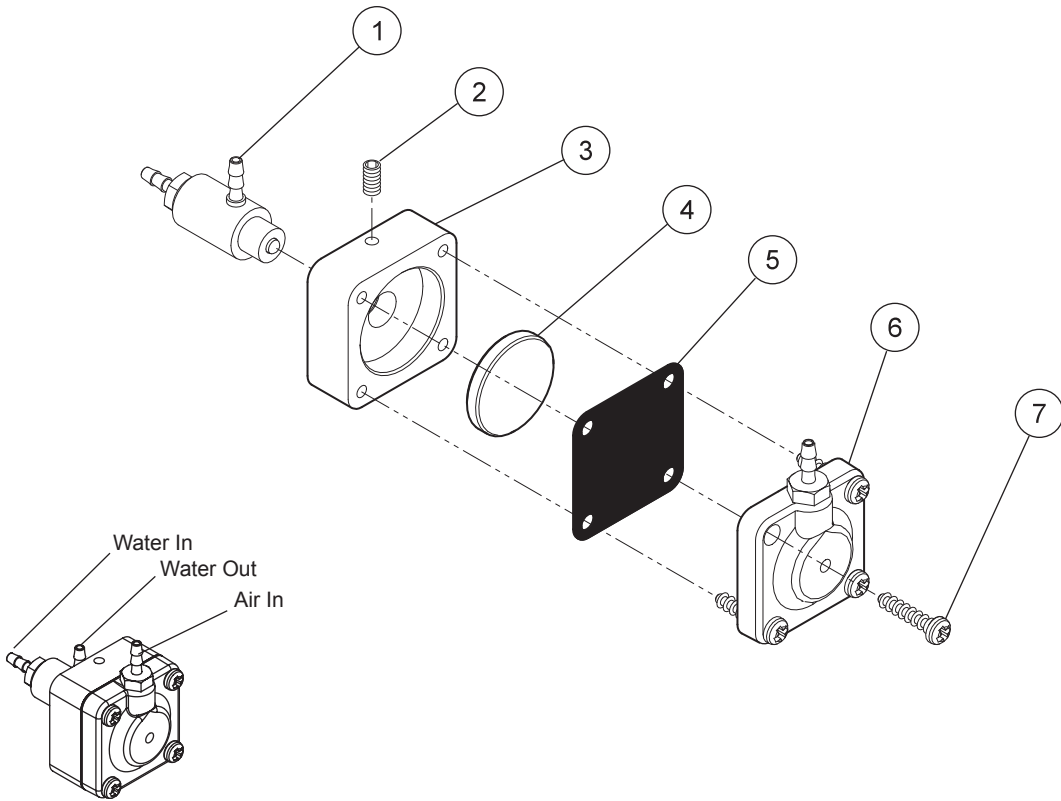
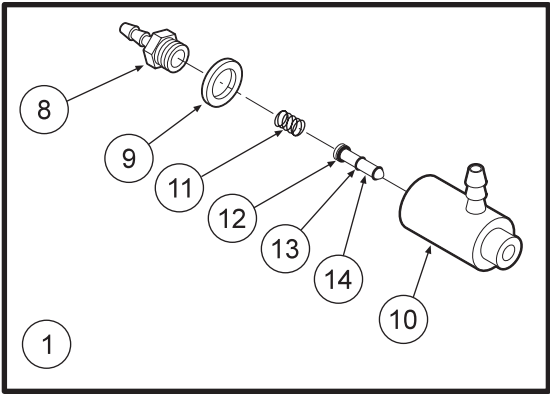

Water Relay Valve 123-000

ITEM	PART DESCRIPTION	PART NUMBER	QTY
1	Cartridge Body Assembly.....	123-018	1
2	Set Screw, 4-40 x 5/8".....	005-028	1
3	Body.....	123-013	1
4	Piston.....	123-014	1
5	Diaphragm.....	127-031	1
6	Cap.....	123-012	1
7	Screw, #6 x 1/2".....	001-267	4
8	Barb, 10-32 x 1/16".....	022-009	1
9	Plastic Washer, 1/4".....	003-001	1
10	Valve Body.....	123-017	1
11	Spring.....	008-011	1
12	O-Ring, 002.....	017-502	1
13	O-Ring, 001.....	017-501	2
14	Stem.....	123-015	1

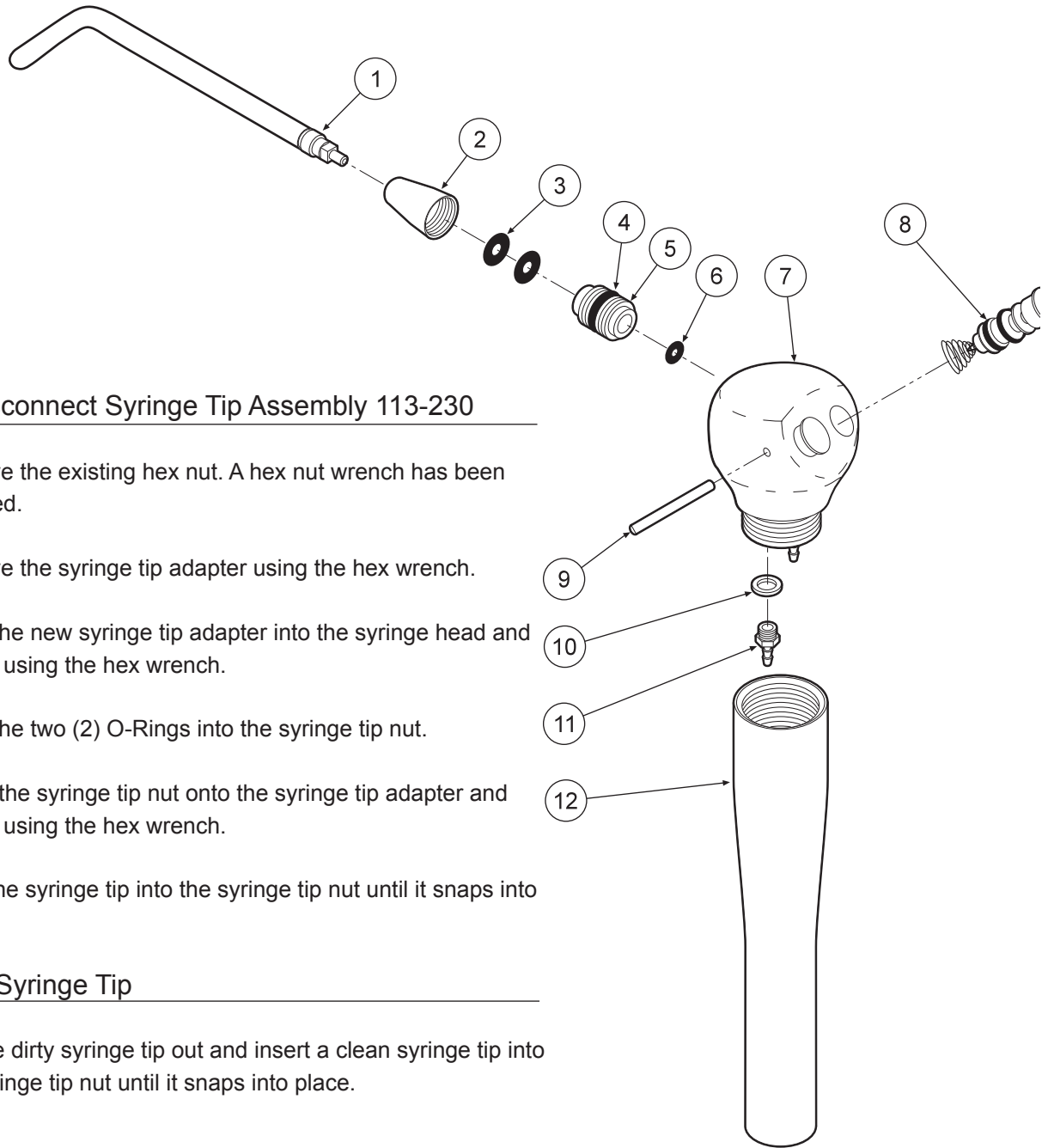

Quick-disconnect Syringe Tip Assembly 113-230

1. Remove the existing hex nut. A hex nut wrench has been provided.
2. Remove the syringe tip adapter using the hex wrench.
3. Insert the new syringe tip adapter into the syringe head and tighten using the hex wrench.
4. Place the two (2) O-Rings into the syringe tip nut.
5. Screw the syringe tip nut onto the syringe tip adapter and tighten using the hex wrench.
6. Push the syringe tip into the syringe tip nut until it snaps into place.

Replace Syringe Tip

1. Pull the dirty syringe tip out and insert a clean syringe tip into the syringe tip nut until it snaps into place.

ITEM	PART DESCRIPTION	PART NUMBER	QTY
1	Syringe Tip	113-030	1
2	Syringe Tip Nut.....	113-402	1
3	O-Ring, 006	017-006	2
4	O-Ring, 228-040	017-023	1
5	Syringe Tip Adapter	113-227	1
6	O-Ring, 003	017-003	1
7	Syringe Head.....	113-405	1
8	Syringe Button Repair Kit	113-403	2
9	Pin, Syringe Cartridge	113-008	1
10	Plastic Washer, 8-32.....	003-030	2
11	Barb, 8-32 x 1/16"	022-040	2
12	Syringe Handle.....	113-236	1

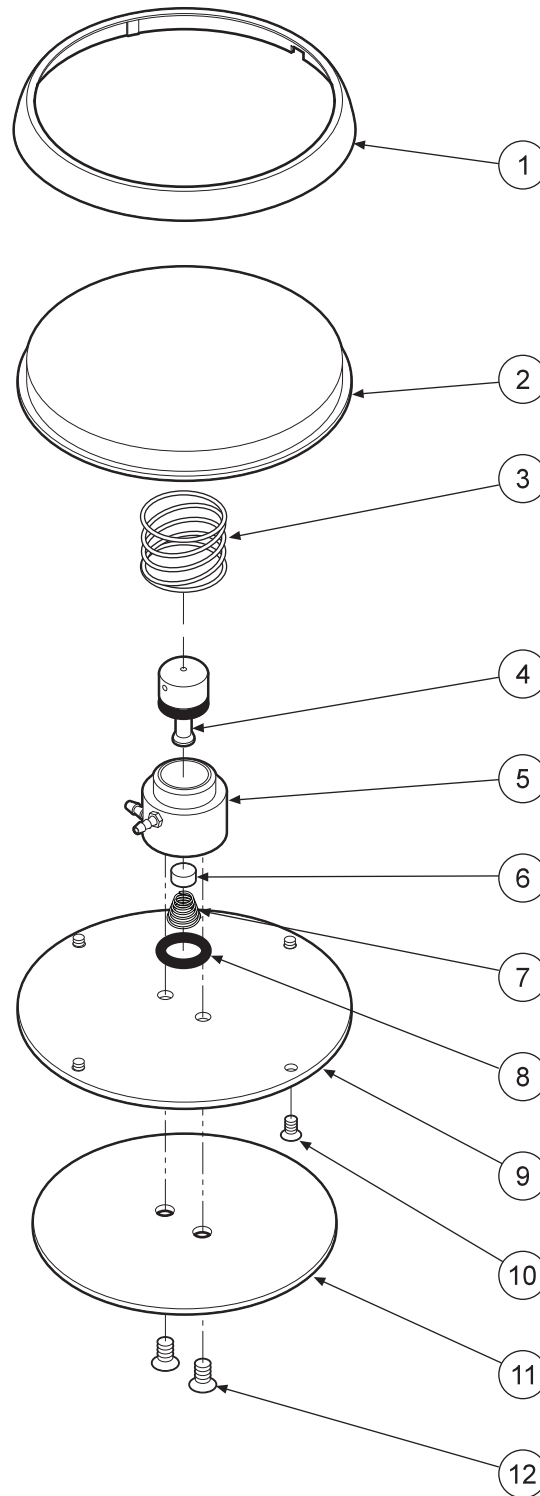

ITEM	PART DESCRIPTION	PART NUMBER	QTY
1	Ring.....	126-202	1
2	Cover.....	126-201	1
3	Spring.....	008-005	1
4	Stem (Includes 017-012 o-ring).....	126-005	1
5	Body.....	126-004	1
6	Poppet.....	126-006	1
7	Spring.....	008-006	1
8	O-Ring, 013.....	017-013	1
9	Baseplate.....	126-003	1
10	Screw, 4-40 x 1/4".....	001-005	4
11	Rubber Pad.....	126-007	1
12	Screw, 6-32 x 1/4".....	001-004	2

FOOT CONTROL
126-200



2 Handpiece Wet Automatic Control A-222

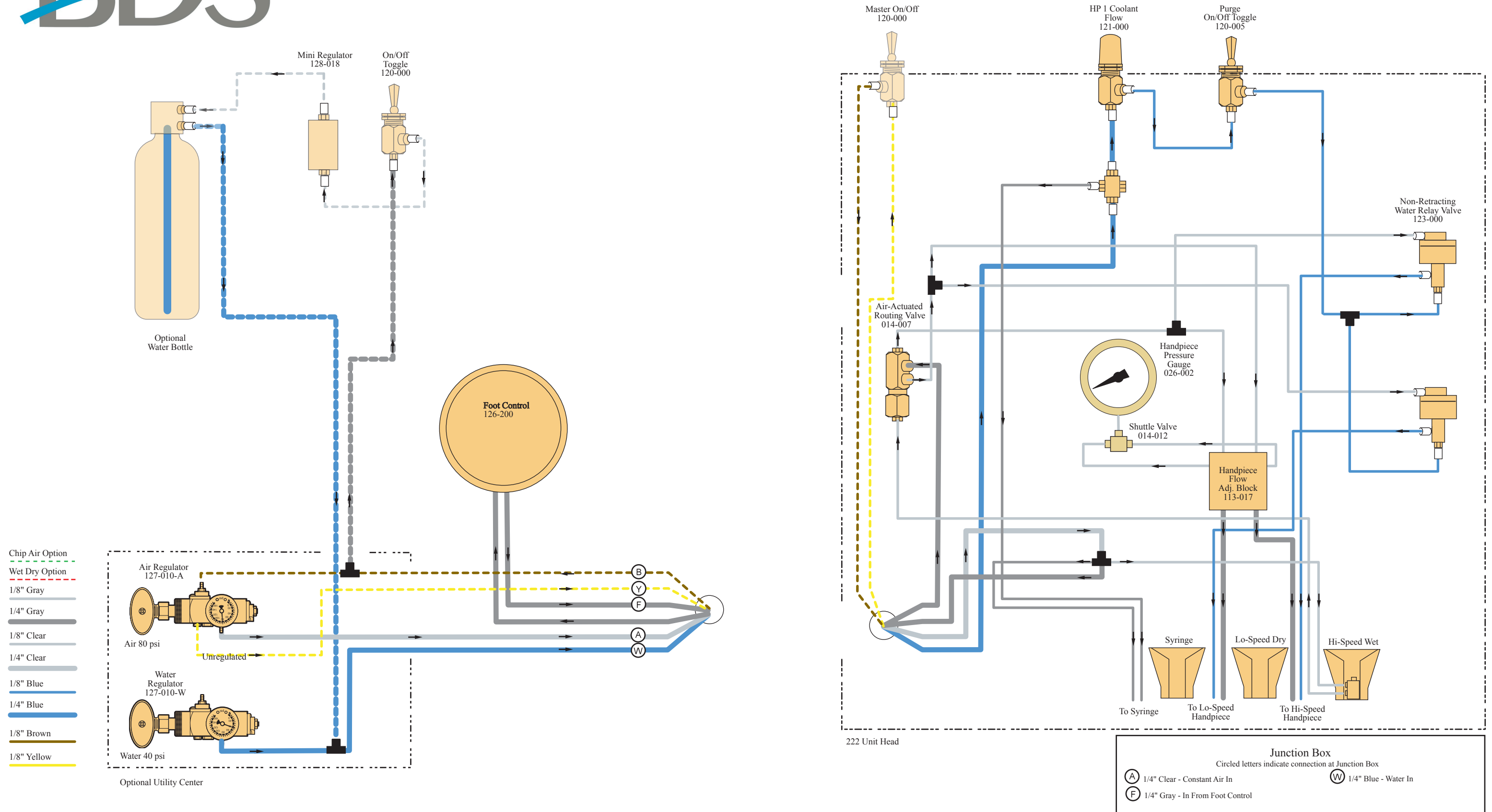

WARRANTY

BDS warrants its product to be free of defects in material and workmanship for SEVEN FULL YEARS from the date of purchase on all units. Auto-blocks and standard foot controls are covered by a LIFETIME warranty when factory installed as part of a complete dental system. Upholstery has a TWO YEAR warranty and does not cover normal wear, stains, cuts or tears. Our LED lights have a FIVE year Warranty and our halogen light has a ONE year Warranty. Operatory chair motors feature a TEN year warranty. All warranty is limited to repair or replacement by BDS. Products returned to the factory and determined to be defective will be repaired or replaced free of charge at discretion of BDS. The warranty does not cover light bulbs, electrical components and trimmed or installed tubing. BDS reserves the right to void all warranties if any product is installed by other than an authorized technician. BDS' warranty does not cover damage to any surface finish, including but not limited to, discoloration or abrasion from cleaners, disinfectants or light sources. No claim for labor or consequential damages will be allowed. Return items must include a copy of the invoice or packing slip as proof of purchase.

**Beaverstate Dental Inc.
115 S. Elliott Rd.
Newberg, OR 97132
800-237-2303
503-538-8756
503-538-2845 Fax
www.beaverstatedental.com**
