



Service Manual

A-5150

Rear Delivery Assistant's Swivel
Vacuum System

Installation

1. Place the shipping carton in the desired location. Remove the unit with pivot arm system from the shipping carton.
2. Mark 4 hole locations under the shelf and pre-drill holes for the mounting screws.
3. Align the drilled holes with the holes on the mounting bracket. Insert 4 screws and fasten the mounting bracket securely to the underside of the shelf.
4. Insert the rigid arm into the block on the mounting bracket. Feed the umbilical through the hole in the mounting bracket and connect the drain and syringe tubing to the appropriate connections.
5. Place the HVE and S/E valves in their holders and connect the tubing to the ports on the vacuum cannister.
6. Place the syringe in its holder.

Final Adjustments

Check air pressure, adjust to 80 psi if necessary.
Check water pressure, adjust to 40 psi if necessary.
Check vacuum cannister for solids screen.
Test HVE and S/E valves for proper function.
Test syringe for proper pressure and function.

Operation

1. Insure that the central vacuum system is turned on and air and water pressures are at the proper setting.
2. Lift the vacuum valve out of the holder and push the lever down towards the base of the valve to allow vacuum to begin.

Cleaning

1. Separate valve from tubing at the quick disconnect swivel by pulling them apart. Remove the lever and the spool and clean in an ultrasonic cleaner.
2. Rinse thoroughly before putting components into autoclave.
3. Lubricate O-Rings on the spool with a silicone based lubricant and reassembly.

Autoclavable HVE & S/E Valves

Maintenance Autoclavable vacuum valves may be autoclaved by steam autoclave or a chemical vapor. Due to the tight clearances and hardness of the anodized surfaces, the valve spool can become jammed or seize in the valve if it is sterilized while contaminated with debris.

Valves can be quickly disassembled for cleaning.

1. Pry one side of the lever and flip it off of the valve. For saliva ejector valves, remove the tip also.
2. Push out the valve spool and clean all the disassembled parts in an ultrasonic cleaner daily. *Rinse thoroughly before putting into autoclave.*
3. Lubricate the O-Rings on the spool with a silicone based lubricant before reassembly.

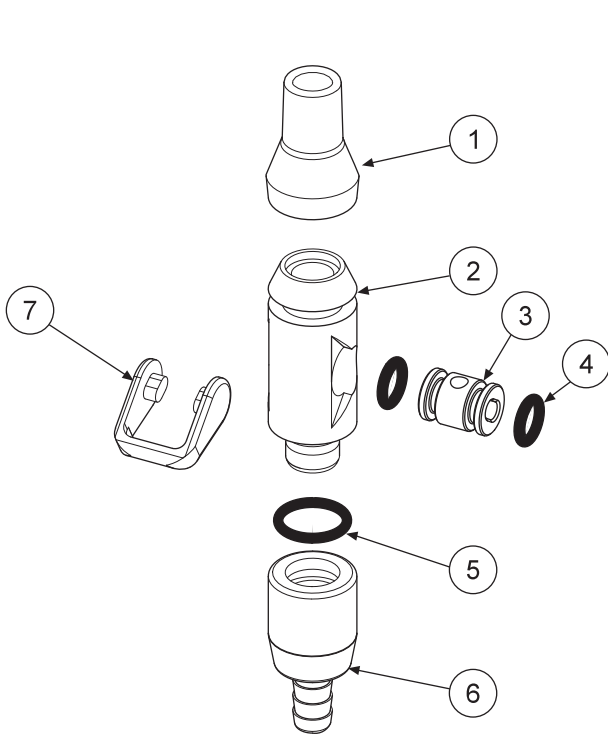

ITEM	PART DESCRIPTION	PART NUMBER	QTY
1	Tip.....	112-174	1
2	Body.....	112-276	1
3	Spool.....	112-278	1
4	O-Ring #10.....	017-110	2
5	O-Ring, #12.....	017-012	1
6	Swivel.....	112-177	1
7	Lever.....	112-181	1

AUTOCLAVABLE S/E LEVER VALVE
112-280

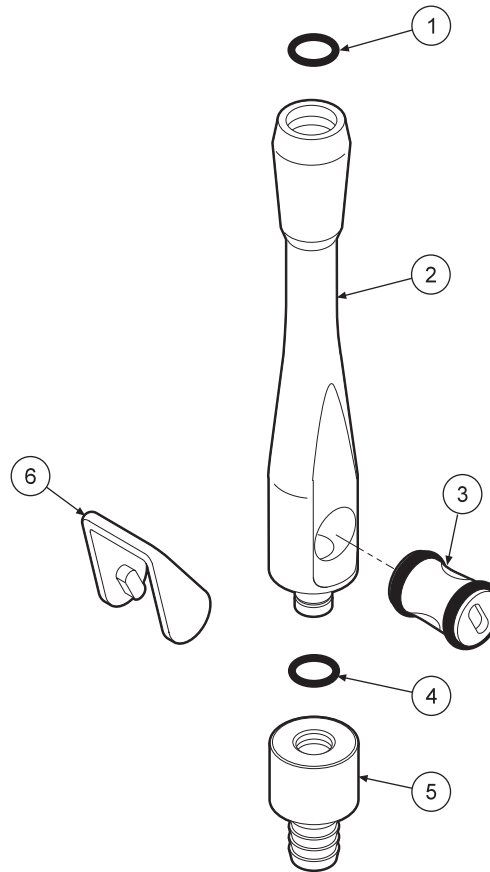

ITEM	PART DESCRIPTION	PART NUMBER	QTY
1	O-Ring, #13.....	017-113	3
2	Body, Chrome.....	112-272	1
3	Spool, Chrome.....	112-268	1
4	O-Ring, #13.....	017-013	1
5	Swivel.....	112-170	1
6	Lever.....	112-169	1

AUTOCLAVABLE UNIVERSAL HVE VALVE
112-263

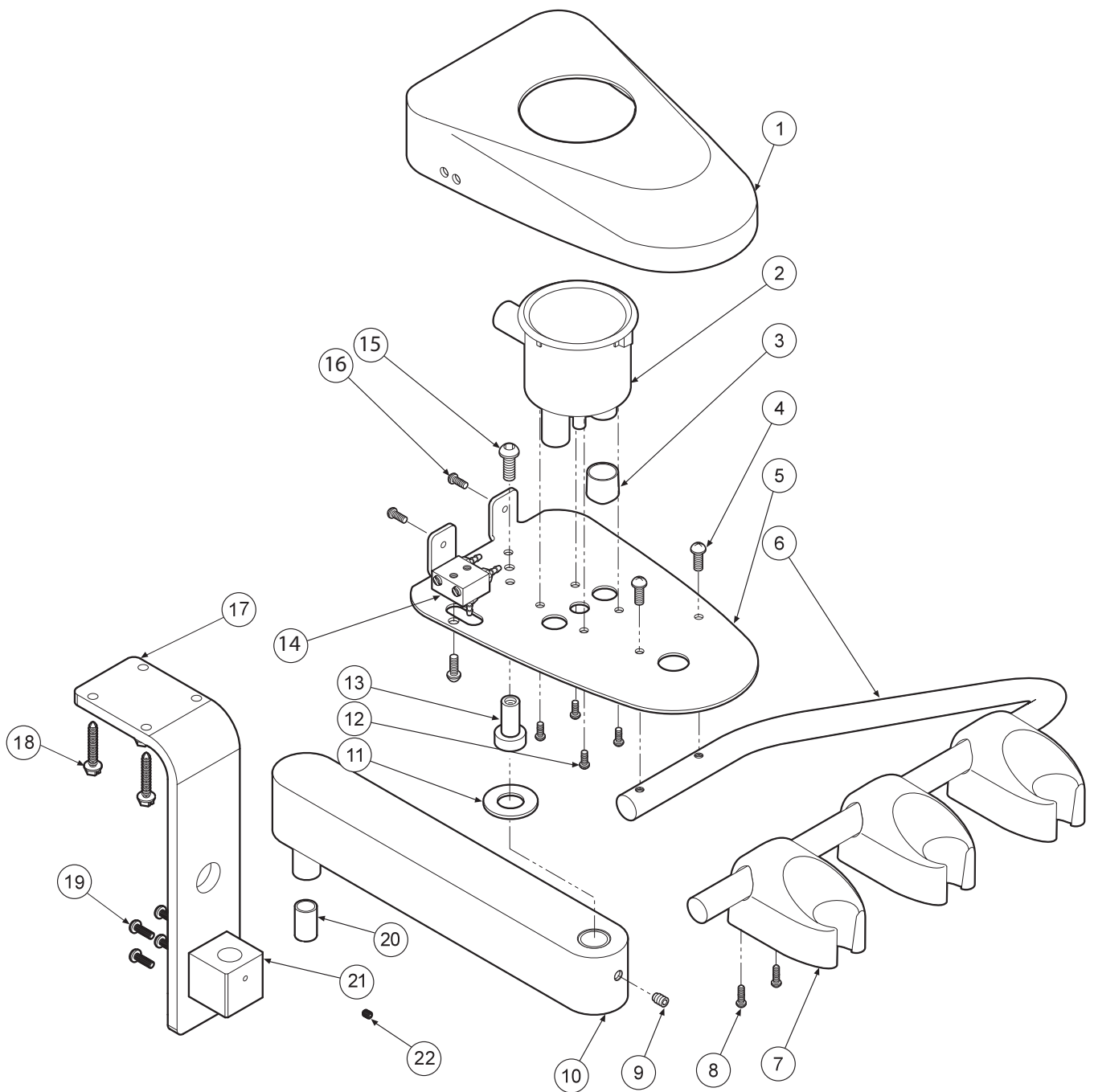

ITEM	PART DESCRIPTION	PART NUMBER	QTY	ITEM	PART DESCRIPTION	PART NUMBER	QTY	ITEM	PART DESCRIPTION	PART NUMBER	QTY
1	Cover.....	105-230	1	9	Set Screw, 10-32 x 1/4".....	005-005	2	16	Screw, 6-32 x 1/4".....	001-133	2
2	Canister.....	131-036	1	10	Arm.....	105-040	2		Rear Delivery Mount	105-130	1
3	HVE Port Plug.....	010-009	1	11	Washer, 1/2".....	003-006	2	17	Mount, Duo Swing, Cabinet.....	105-050	1
4	Screw, 10-32 3/8".....	001-070	3	12	Screw, 6-32 x 3/8".....	001-134	4	18	Screw, Hex, #14 x 1/4".....	001-137	4
5	Mounting Plate	105-232	1	13	Pivot Pin.....	105-012	1	19	Screw, 10-32 Phillips Round	001-056	4
6	Holder Bar	105-114	1	14	Syringe Block	113-026	1	20	Bushing, Bronze	013-014	1
7	Vacuum Handpiece Holder.....	141-200	3	15	Screw, 1/4-20 x 1".....	001-103	1	21	Block, Wall Mount.....	105-048	1
8	Screw, #8 x 1/2" Phillips, Plastite.....	001-018	6					22	Set Screw	005-026	1

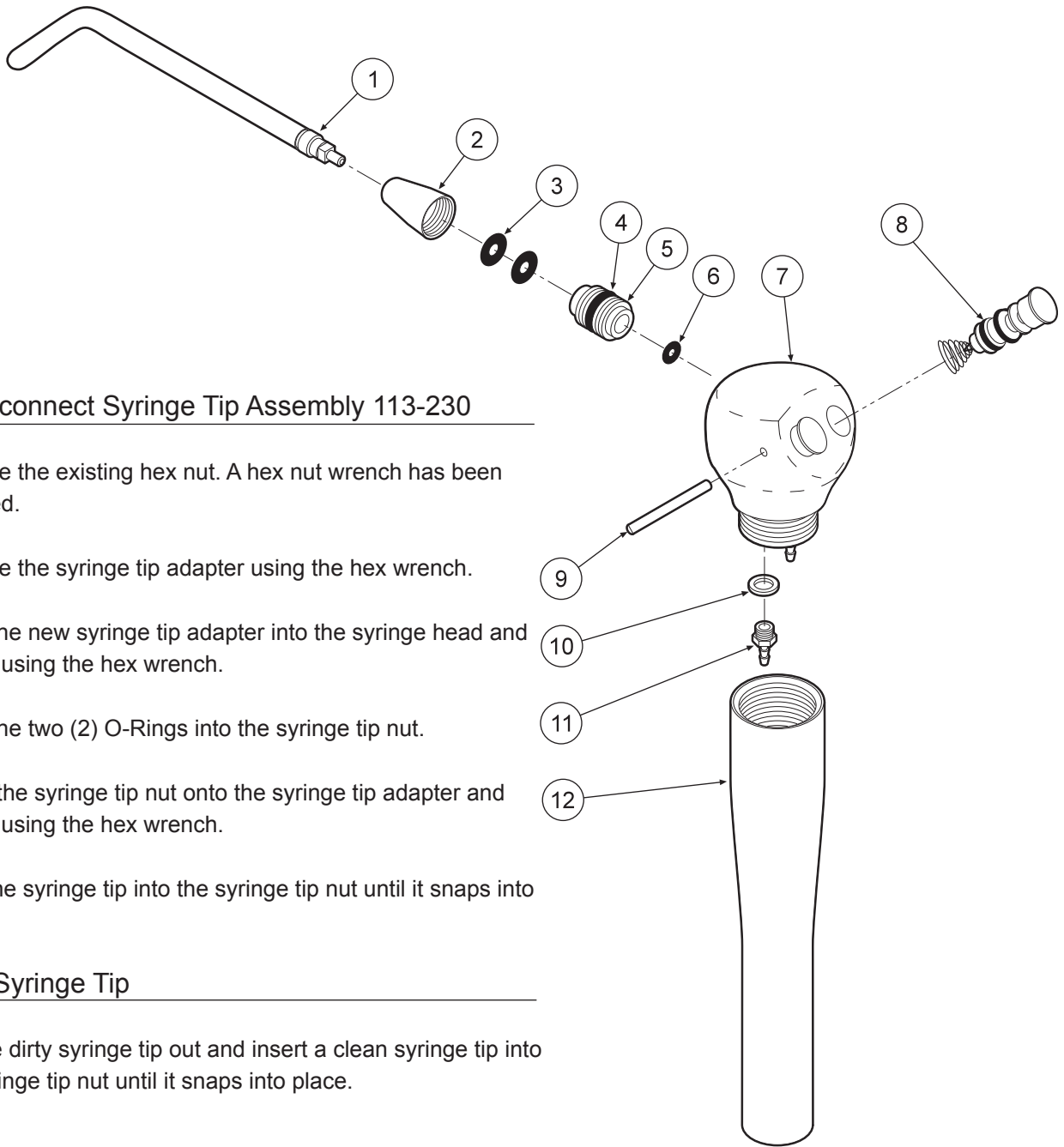

Quick-disconnect Syringe Tip Assembly 113-230

1. Remove the existing hex nut. A hex nut wrench has been provided.
2. Remove the syringe tip adapter using the hex wrench.
3. Insert the new syringe tip adapter into the syringe head and tighten using the hex wrench.
4. Place the two (2) O-Rings into the syringe tip nut.
5. Screw the syringe tip nut onto the syringe tip adapter and tighten using the hex wrench.
6. Push the syringe tip into the syringe tip nut until it snaps into place.

Replace Syringe Tip

1. Pull the dirty syringe tip out and insert a clean syringe tip into the syringe tip nut until it snaps into place.

ITEM	PART DESCRIPTION	PART NUMBER	QTY
1	Syringe Tip	113-030	1
2	Syringe Tip Nut.....	113-402	1
3	O-Ring, 006	017-006	2
4	O-Ring, 228-040	017-023	1
5	Syringe Tip Adapter.....	113-227	1
6	O-Ring, 003	017-003	1
7	Syringe Head.....	113-405	1
8	Syringe Button Repair Kit	113-403	2
9	Pin, Syringe Cartridge	113-008	1
10	Plastic Washer, 8-32.....	003-030	2
11	Barb, 8-32 x 1/16"	022-040	2
12	Syringe Handle.....	113-236	1



Cabinet Mount Vacuum System A-5150

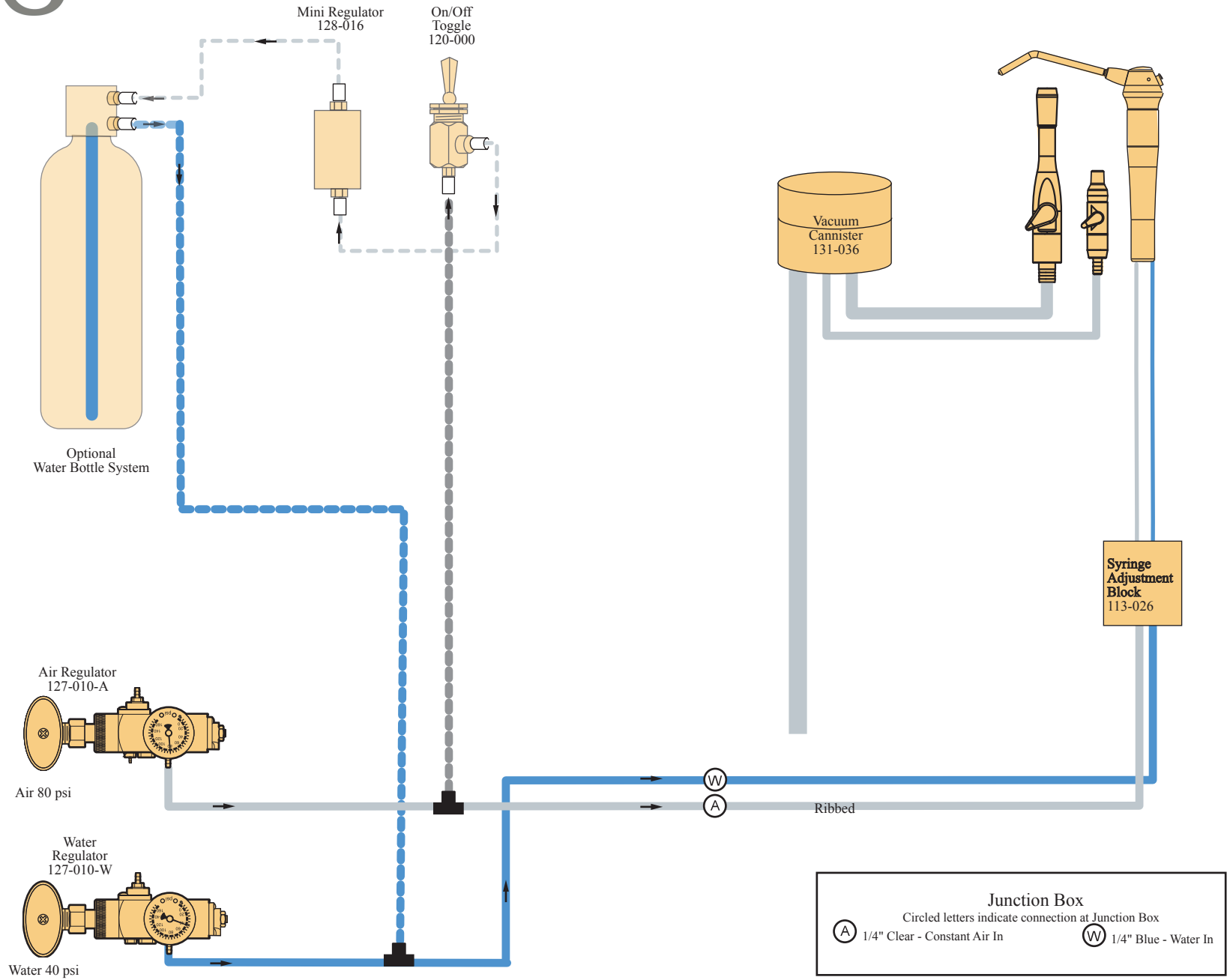

WARRANTY

BDS warrants its product to be free of defects in material and workmanship for SEVEN FULL YEARS from the date of purchase on all units. Auto-blocks and standard foot controls are covered by a LIFETIME warranty when factory installed as part of a complete dental system. Upholstery has a TWO YEAR warranty and does not cover normal wear, stains, cuts or tears. Our LED lights have a FIVE year Warranty and our halogen light has a ONE year Warranty. Operator chair motors feature a TEN year warranty. All warranty is limited to repair or replacement by BDS. Products returned to the factory and determined to be defective will be repaired or replaced free of charge at discretion of BDS. The warranty does not cover light bulbs, electrical components and trimmed or installed tubing. BDS reserves the right to void all warranties if any product is installed by other than an authorized technician. BDS' warranty does not cover damage to any surface finish, including but not limited to, discoloration or abrasion from cleaners, disinfectants or light sources. No claim for labor or consequential damages will be allowed. Return items must include a copy of the invoice or packing slip as proof of purchase.

**Beaverstate Dental Inc.
115 S. Elliott Rd.
Newberg, OR 97132
800-237-2303
503-538-8756
503-538-2845 Fax
www.beaverstatedental.com**
